



FROG-D 3P
FREQUENCY READOUT OF GENERATOR
THREE PHASE
GENERATOR DISPLAY
MODELS: FDA700 for Delta Winding
FDA710 for Star Winding



FIRE RESEARCH CORPORATION

www.fireresearch.com

26 Southern Blvd., Nesconset, NY 11767

TEL 631.724.8888 FAX 631.360.9727 TOLL FREE 1.800.645.0074

CONTENTS

Table of Contents

CONTENTS.....	2
INTRODUCTION	3
Overview.....	3
Features.....	3
Specifications.....	3
GENERAL DESCRIPTION	4
Components	4
Controls and Indicators.....	5
INSTALLATION	6
Install Display Module.....	6
Install Signal Interface Module.....	6
Install Current Sensor	8
Install Voltage Transformer.....	8
Install Optional Temperature Sensor	8
Install Optional Buzzer	8
OPERATION	10
WIRING.....	12
Connectors and Cables.....	12
Voltage Transformers.....	14
Current Sensors.....	15
Star Winding Connections	16
Delta Winding Connections	17

List of Figures/Table

Figure 1. Controls and Indicators.....	5
Figure 2. Display Module Mounting Dimensions	7
Figure 3. Signal Interface Module Mounting Dimensions	7
Figure 4. Current Sensor.....	9
Figure 5. Voltage Transformer	9
Table 1. Line Displays	11
Figure 6. Display Module Wiring	12
Figure 7. Signal Interface Module Wiring	13
Figure 8. Voltage Transformer Wiring	14
Figure 9. Current Sensor Wiring.....	15
Figure 10. Star Winding Connections.....	16
Figure 11. Delta Winding Connections.....	17

INTRODUCTION

Overview

The three phase generator output display panel is rated for 50/60 Hz generators from 10 to 135 kW with delta or star windings.

The display module has ultra-brite LEDs that show the generator frequency, voltage, and current. When the generator is off line the display shows total accumulated generator hours.

The signal interface module is mounted close to the current sensors and voltage transformers so that cable runs are short. Current and voltage information is passed to the display module over a two wire datalink.

Built in safety features include voltage fluctuation, current overload and high temperature warnings.

Features

Generator Hourmeter

Audible Alarm Buzzer (Optional)

Temperature Sensor (Optional)

Specifications

Display Module

Dimensions: 4 1/4" Wide by 4 1/4" High

Control Box

Supply Power: 12 VDC

Supply Current: 1.25 Amps

Dimensions: 5 7/8" by 3 3/4" by 1 7/8"

Current Sensor

Winding Ratio: 150 : 5

Voltage Transformer

Input: 120/240 VAC

Output: 12/24 VAC @ 0.2A

GENERAL DESCRIPTION

Components

The three phase generator display consist of the following components:

Display Module

Signal Interface Module

Three (3) Current Sensors

Three (3) Voltage Transformers

Temperature Sensor (Optional)

Audible Alarm Buzzer (Optional)

Cables

Display Module

The display module is waterproof and can be mounted anywhere on the electrical panel. The display module has a square flange with overall dimensions of 4 1/4" by 4 1/4". A cutout hole of 3 3/4" in diameter is required.

Signal Interface Module

The signal interface module is waterproof with overall dimensions of 5 7/8" by 3 3/4" by 1 7/8". Clearance for the cables is required. This module is mounted close to the current sensors and voltage transformers so the cable runs are short. Current and voltage information is passed to the display module over a two wire datalink.

Current Sensor

The current sensors are used to measure current flow through a wire by electromagnetic induction. Each phase wire to the main circuit breaker is run through a current sensor opening (hole); one wire through each current sensor.

Voltage Transformer

The voltage transformers supplied work with 120 or 240 volt AC systems. The transformers should be securely mounted inside the electrical box.

Temperature Sensor (Optional)

The optional temperature sensor is installed as required.

Audible Alarm Buzzer (Optional)

The optional buzzer is installed as required.

Cables

Refer to the Wiring Section.

Controls and Indicators

There is a STATUS LED located on the control box. All other controls and indicators are located on the front of the display module.

FREQUENCY Hz Display

Shows generator frequency in hertz.

LINE Displays

Shows a number that corresponds to a line in the chart to the left of the display.

VAC VOLTAGE Display

Shows the generator output in volts of the selected line.

AMPS CURRENT Display

Shows the current in ampers of the selected line.

MODE Button

Press to show total generator hours and sensor temperature.

LINE Button

Selects the line from the chart that is shown on the voltage and current displays. See Operation Section for complete description.

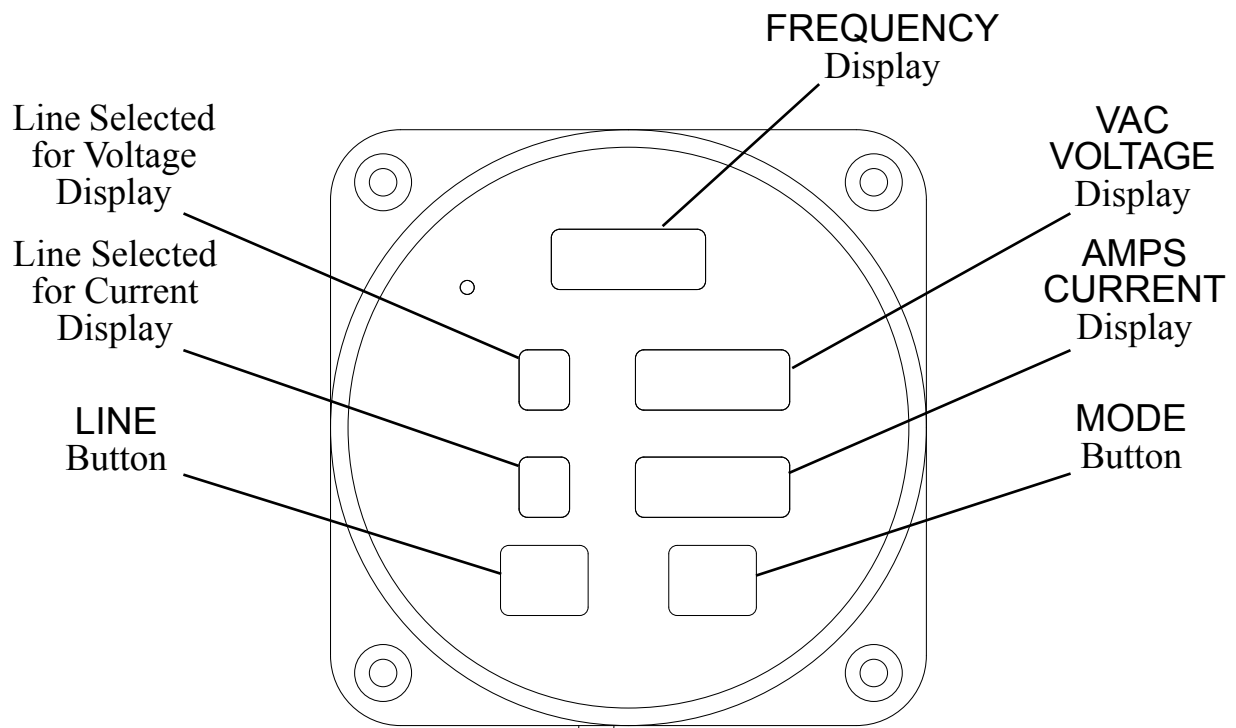

Figure 1. Controls and Indicators

INSTALLATION

Ensure that the generator power rating and the display rating match. Refer to Programming Section.

Install Display Module

1. Measure and mark mounting location for display module panel cutout and mounting screw holes. Make sure there is clearance behind the panel for the module and cables before cutting holes. Refer to Figure 2 for layout and dimensions.
2. Cut out a 3 3/4" mounting hole in panel.
3. Drill four holes, clearance or tapped, for #10 mounting screws.
4. Place display module in position and secure with screws.
5. Connect cable at rear of the display module. (Refer to Wiring Section.)

Install Signal Interface Module

This module is mounted close to the current sensors and voltage transformers so the cable runs are short. Current and voltage information is passed to the display module over a two wire datalink.

1. Measure and mark mounting location for control box mounting screw holes. Make sure there is clearance for the box and cables before drilling. Refer to Figure 3 for layout and dimensions.
2. Drill four holes, clearance or tapped, for #8 mounting screws.
4. Place box in position and secure with screws.
5. Connect cables at top of the box. (Refer to Wiring Section.)

Display Module

Mounting holes are clearance or tapped for #10 screws.

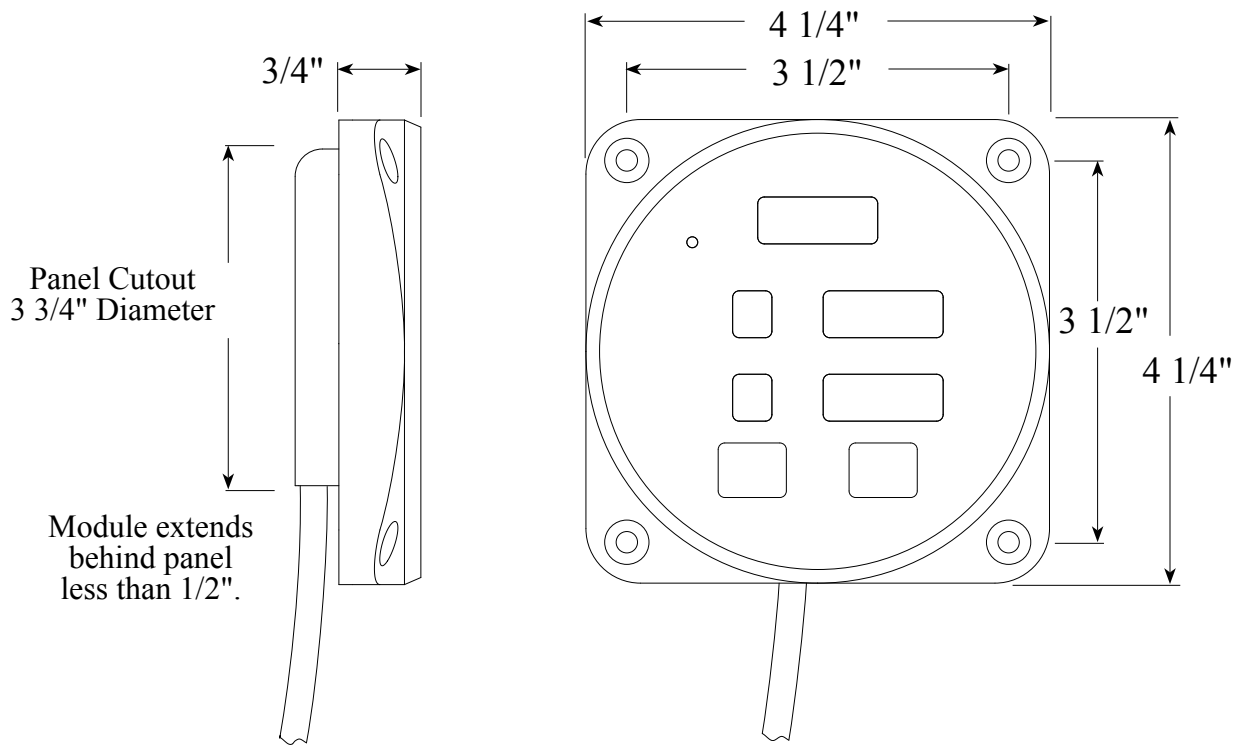

Figure 2. Display Module Mounting Dimensions

Control Box

Mounting holes are clearance or tapped for #8 screws.

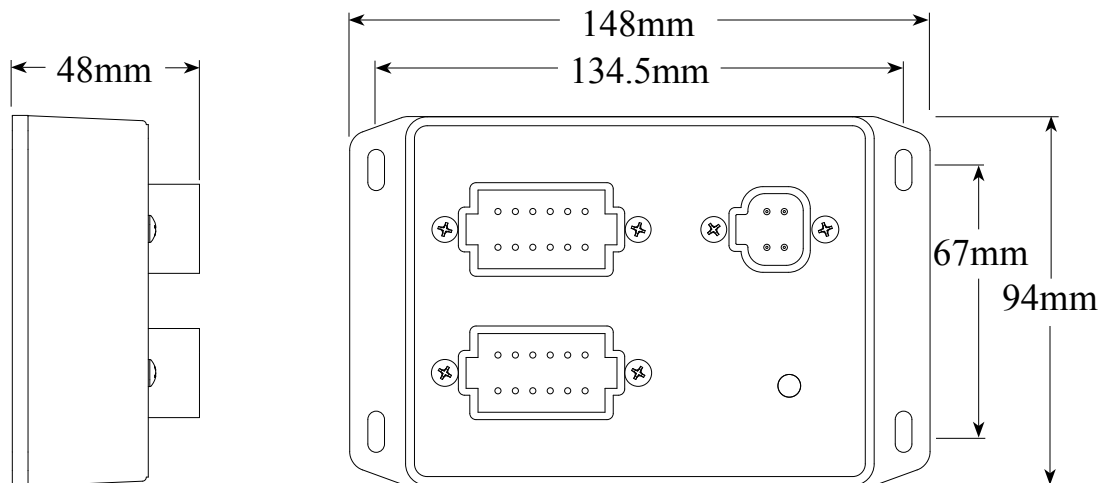

Figure 3. Signal Interface Module Mounting Dimensions

Install Current Sensor

Three current sensors are supplied. It is best to mount the sensors in the circuit breaker box. For each phase that is to be monitored, run the wire from the generator through the current sensor opening (hole) to the input side of the circuit breaker. (Refer to Wiring Section.)

Install Voltage Transformer

The voltage transformers supplied will work for 120 or 240 volt AC systems. The transformers should be securely mounted inside the electrical box.

Each transformer will be connect to show line voltage phase and neutral or phase to phase for star or delta windings of the generator. (Refer to Wiring Section.)

Install Optional Temperature Sensor

The temperature sensor is installed as required. (Refer to Wiring Section.)

Install Optional Buzzer

Install the buzzer close to the control module so the audible warning is easily associated with the visual warning on the display. The optional buzzer provided by FRC requires a cutout hole of 1-1/8" (1.125"). (Refer to Wiring Section.)

Current Sensor

Ratio: 150 : 5

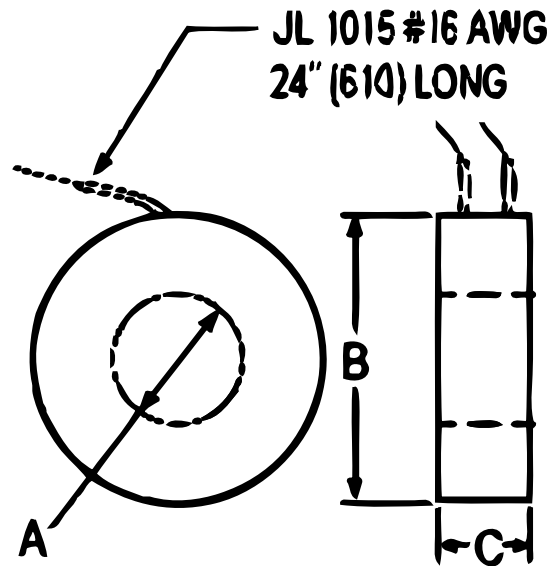

Dimensions

A = 1.13"
 B = 2.46"
 C = 1.05"

Figure 4. Current Sensor

Voltage Transformer

Input: 120/240 VAC
 Output: 12/24 VAC @ 0.2A

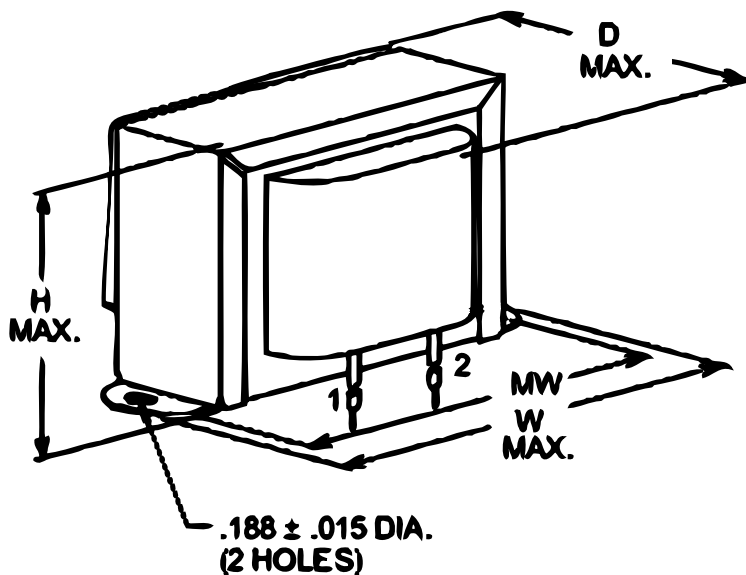

Dimensions

D = 1 1/2"
 H = 1 3/8"
 W = 2 3/8"
 MW = 2"

Figure 5. Voltage Transformer

OPERATION

On power-up the display shows the kW rating and the winding type (delta or star) for three seconds.

MODE Button

During normal operations the mode button is used to display the accumulated hours and hydraulic oil temperature if this option is installed.

The first time the MODE button is pressed, the display shows generator hours.

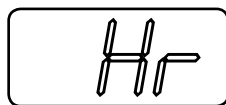

**Generator Operating Time is:
50 hours**

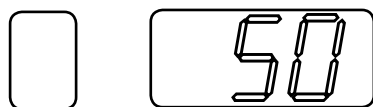

Pressing the MODE button again switches the display to show sensor temperature.

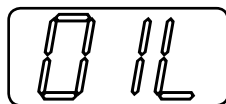

**Hydraulic Oil Temperature is:
150 degrees F**



Pressing the MODE button again returns the display to normal operations.

Over Current Warning

When the generator is operating outside the range of its rated capacity, the current display flashes. An optional audible buzzer can also be connected for audio warning.

Voltage Out-Of-Range Warning

If the output voltage (120/240 VAC) is below 80/200 VAC or above 140/270 VAC, the voltage display flashes. This gives the operator an indication that the generator output falls outside the safe operating level. There is no audible alarm for the voltage out of range warning.

Temperature Sensor(Optional)

This warning is activated if the temperature sensor rises above 180 °F. The frequency readout flashes OIL to warn the operator and the audio alarm is activated.

LINE Displays and Button

On power up the LINE displays are set to auto.

In auto the displays scroll continuously through all selectable options and show the corresponding voltages and currents in the display windows.

To read the voltage and current for a specific line press and hold the LINE button until the number corresponding to the desired selection shows in the LINE window. (Refer to the chart next to the LINE window.)

Note: When line selections 4, 5, and 6 are active the AMPS window shows 3 dashes.

Leave the display in auto during normal operations to monitor all voltage and current levels.

Table 1. Line Displays

Line Window Chart	Description
1.A-N	Shows Voltage Phase A to Neutral
2.B-N	Shows Voltage Phase B to Neutral
3.C-N	Shows Voltage Phase C to Neutral
4.A-B	Shows Voltage Phase A to Phase B
5.B-C	Shows Voltage Phase B to Phase C
6.C-A	Shows Voltage Phase C to Phase A
7.Auto	Scroll Continuously Through All Selectable Options
1.A	Shows Current on Phase A
2.B	Shows Current on Phase B
3.C	Shows Current on Phase C

WIRING

The following figures include the schematics, wiring diagrams, block diagrams, and cables for the three phase generator display system.

Connectors and Cables

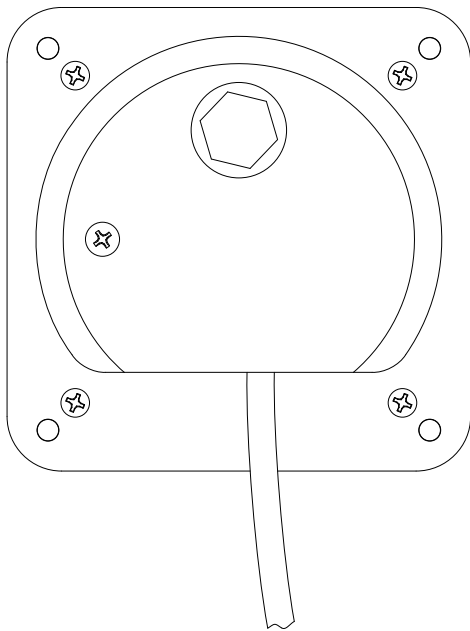

6 Pin Connector and Cable		
Pin	Wire Color	Description
1	Red	+12 VDC
2	Black	-12 VDC
3	White	Datalink (+)
4	Green	Datalink (-)
5	Blue	Buzzer +12 VDC
6	Brown	Buzzer Ground

Note: The 6-Pin connector from the display module is wired to the signal interface module 4-Pin connector. The two buzzer wires are pig-tailed off.

Dual Display

For a dual display configuration a 4-Pin Y-cable (FRC P/N XE-XXDLY4-C1A) is connected to the signal interface module 4-Pin connector. Two display extension cables (FRC P/N XE-FD7DISP2-C10A) and two display modules can be connected.

Figure 6. Display Module Wiring

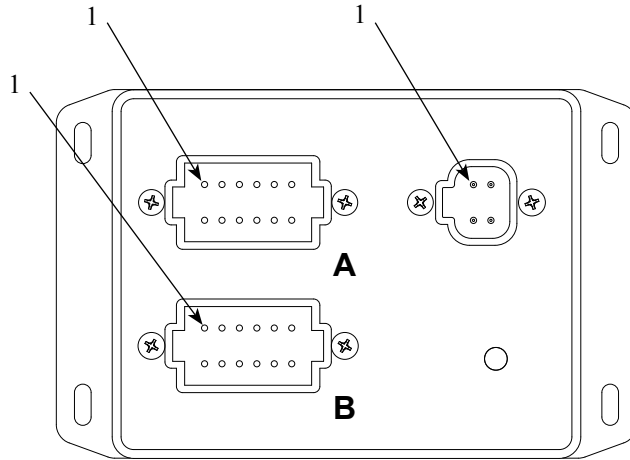

4 Pin Connector and Cable

Pin	Wire Color	Description
1	Red	+12 VDC
2	Black	-12 VDC
3	White	Datalink (+)
4	Green	Datalink (-)

Note: The 4-Pin connector from the signal interface module is wired to the display module 6-Pin connector.

Gray 12 Pin A Connector and Cable

Pin	Wire Color	Description
1	Orange	Temperature Sensor Supply
2	White	Temperature Sensor Signal
3	Green	Temperature Sensor Ground
4		N/C
5		N/C
6		N/C
7		N/C
8		N/C
9		N/C
10		N/C
11	Red	+12 VDC
12	Black	-12 VDC

Black 12 Pin B Connector and Cable

Pin	Wire Color	Description
1	Green	Voltage Transformer 1
2	Blue	Voltage Transformer 1
3	Orange	Voltage Transformer 2
4	White	Voltage Transformer 2
5	Purple	Voltage Transformer 3
6	Tan	Voltage Transformer 3
7	Pink	Current Sensor 1
8	Gray	Current Sensor 1
9	Yellow	Current Sensor 2
10	Brown	Current Sensor 2
11	Red	Current Sensor 3
12	Black	Current Sensor 3

Voltage Transformer
(See Figure 8)

Current Sensors
(See Figure 9)

Figure 7. Signal Interface Module Wiring

Voltage Transformers

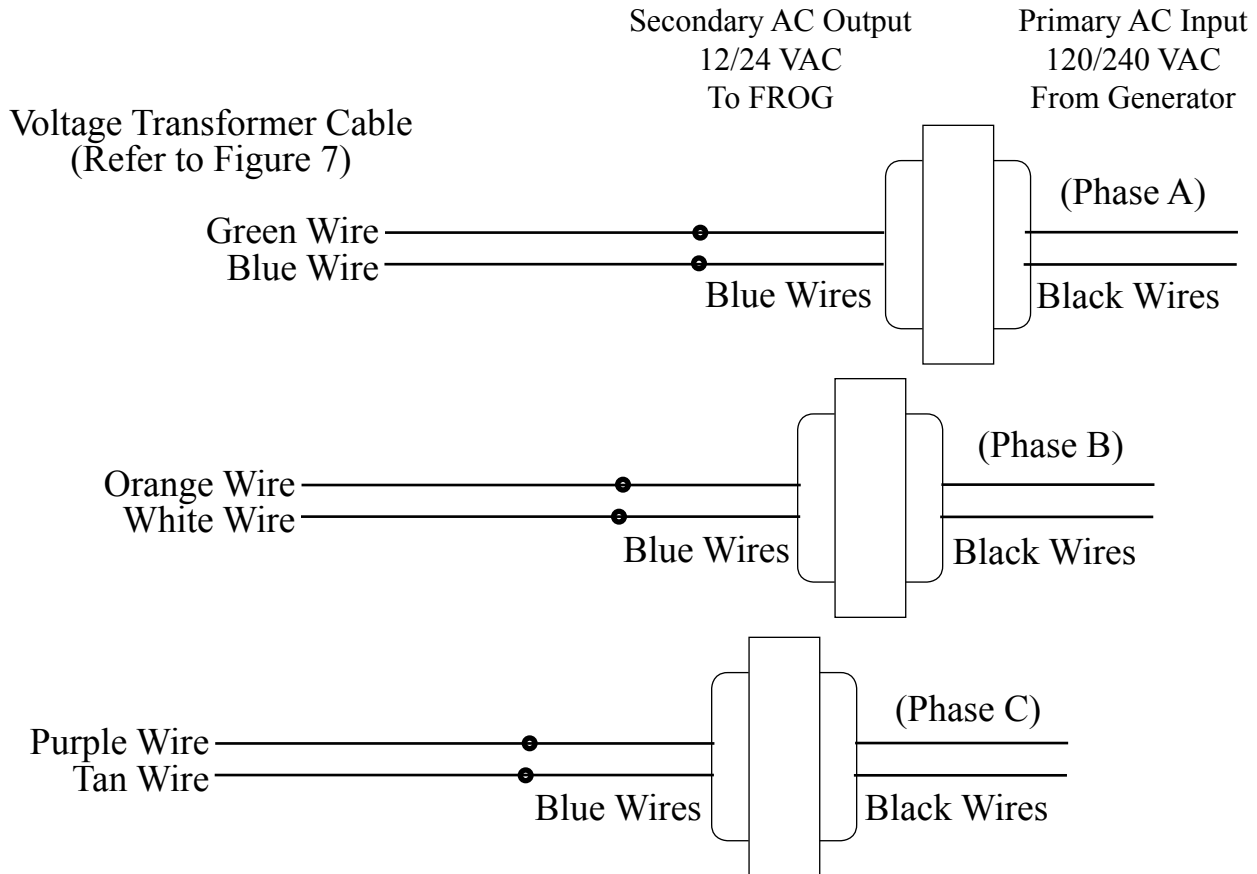

Note: Refer to Star or Delta windings diagrams for generator connections.

Figure 8. Voltage Transformer Wiring

Current Sensors

Current Sensor Cable
(Refer to Figure 7)

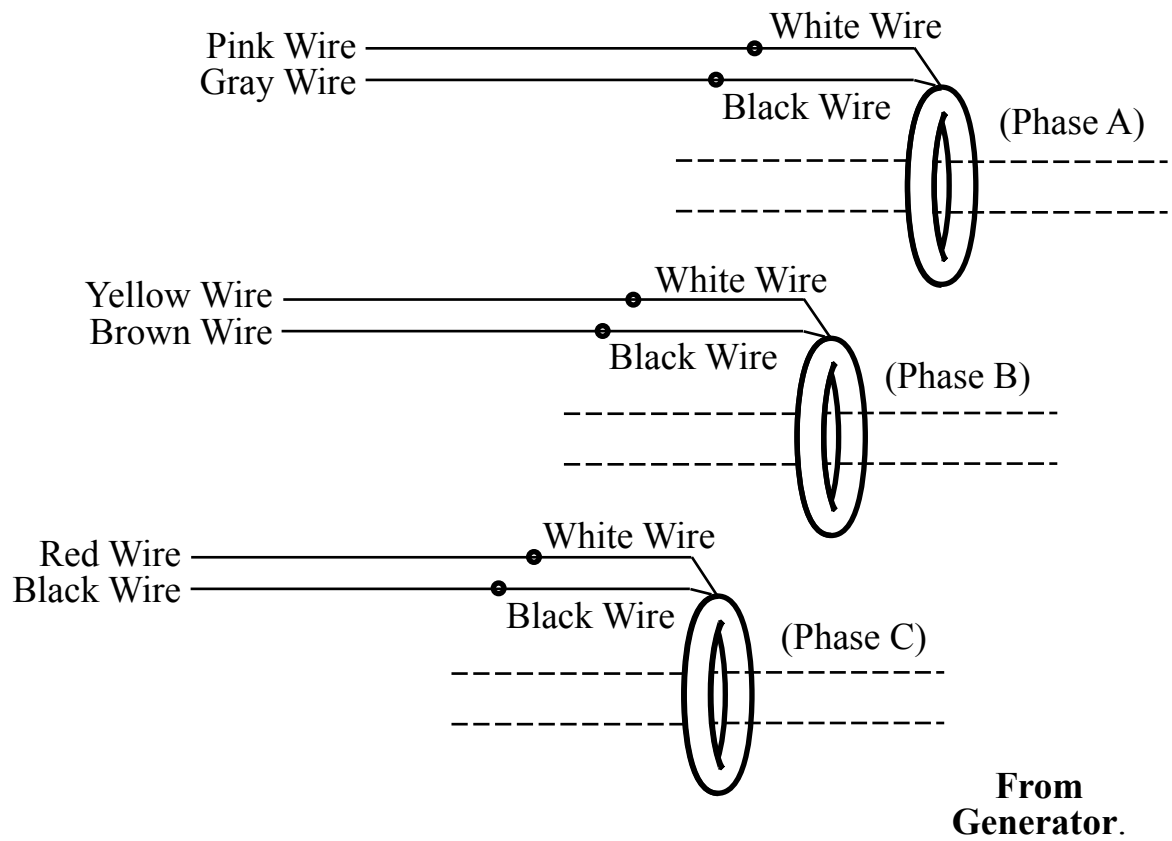
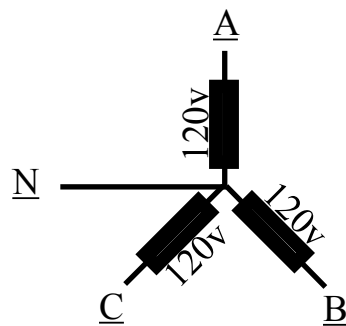
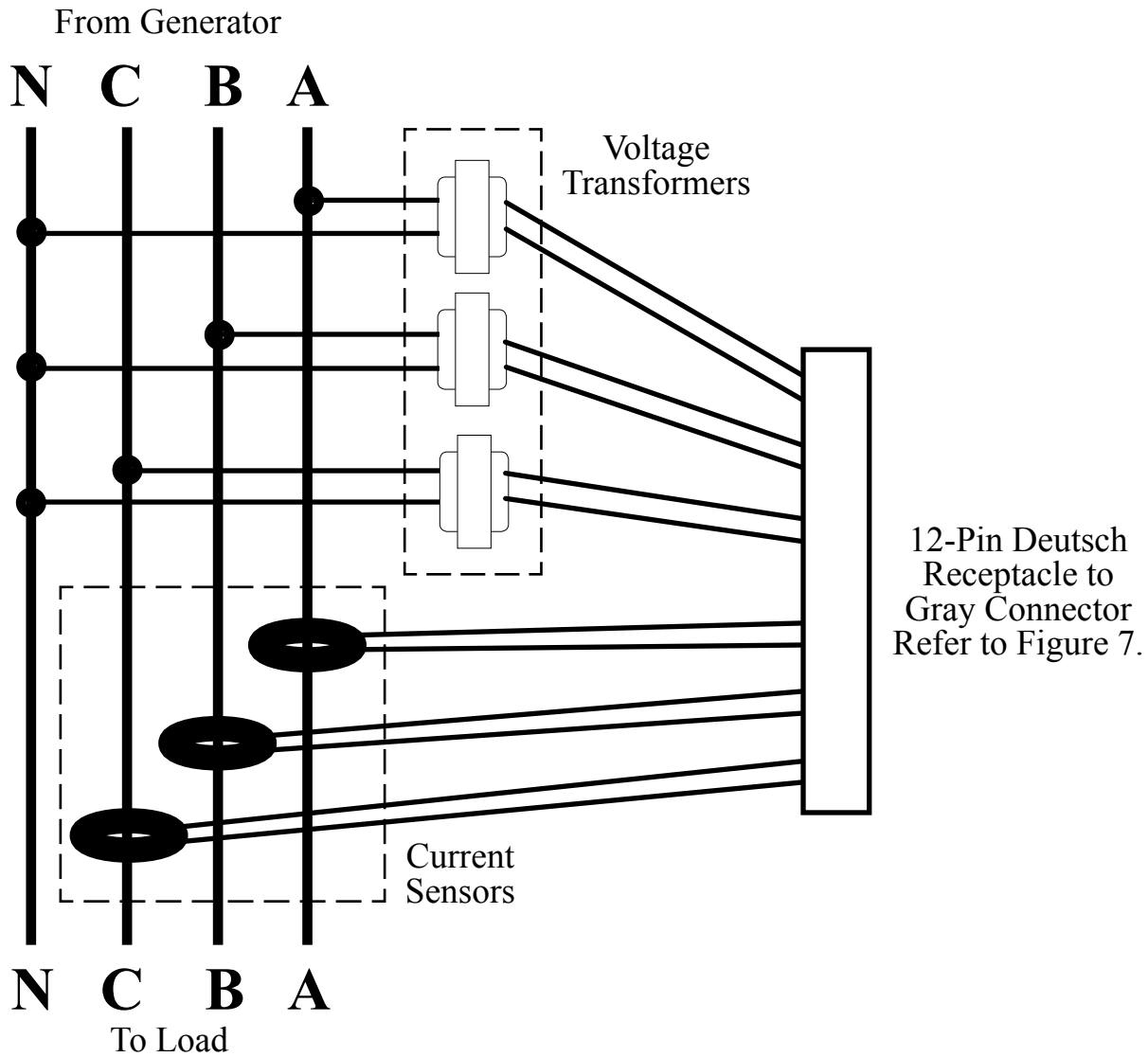

Figure 9. Current Sensor Wiring

Star Winding Connections



Star Circuit

Figure 10. Star Winding Connections

Delta Winding Connections

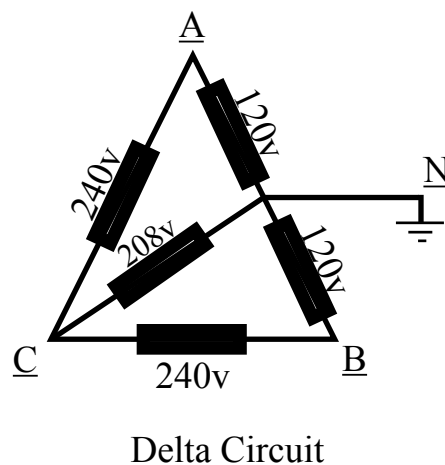
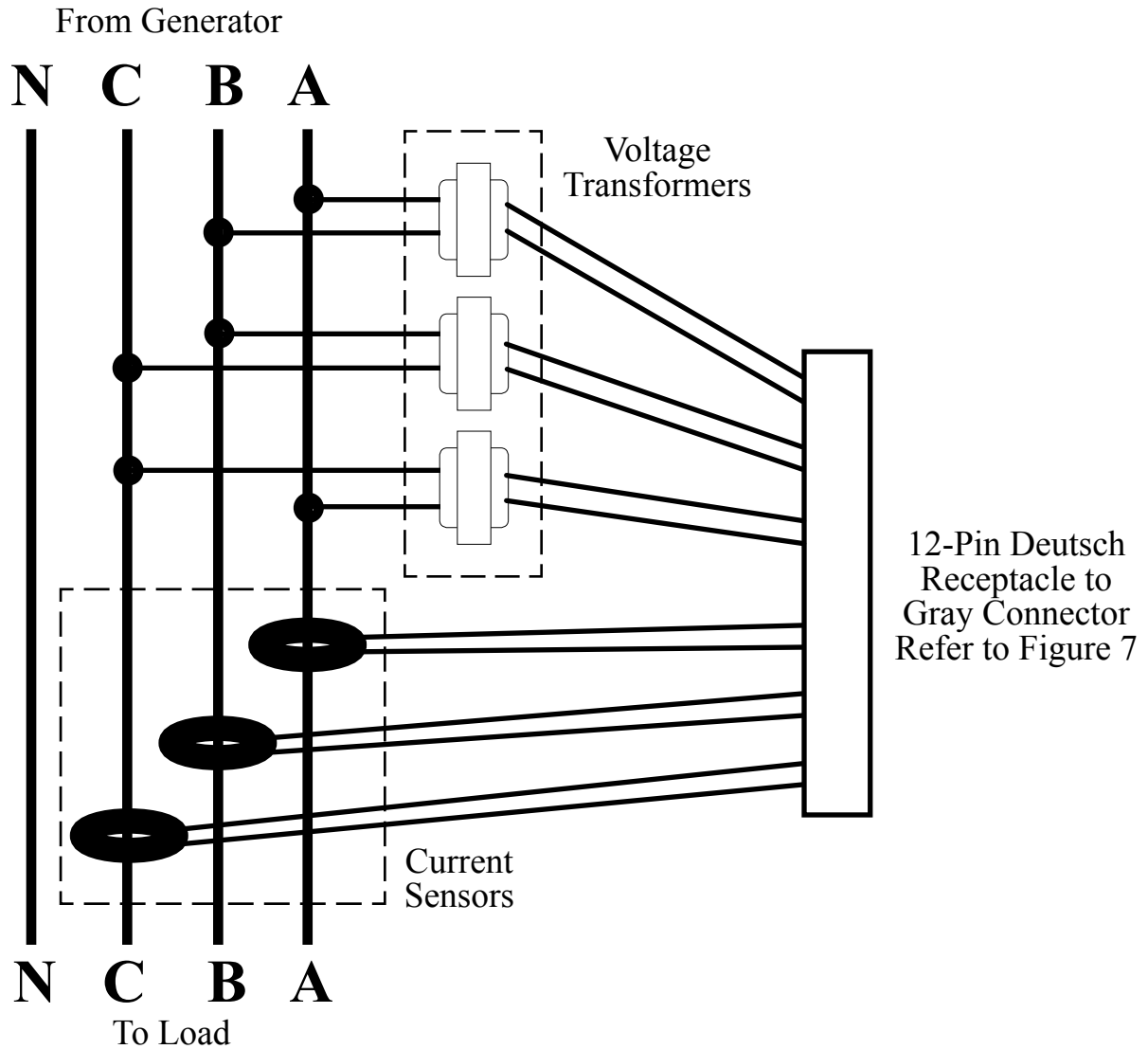

Figure 11. Delta Winding Connections